

# ALIS SYSTEM

## EXAMPLES OF USAGE

---



# innovative LED floor marking



# LED YOUR SAFETY SHINE

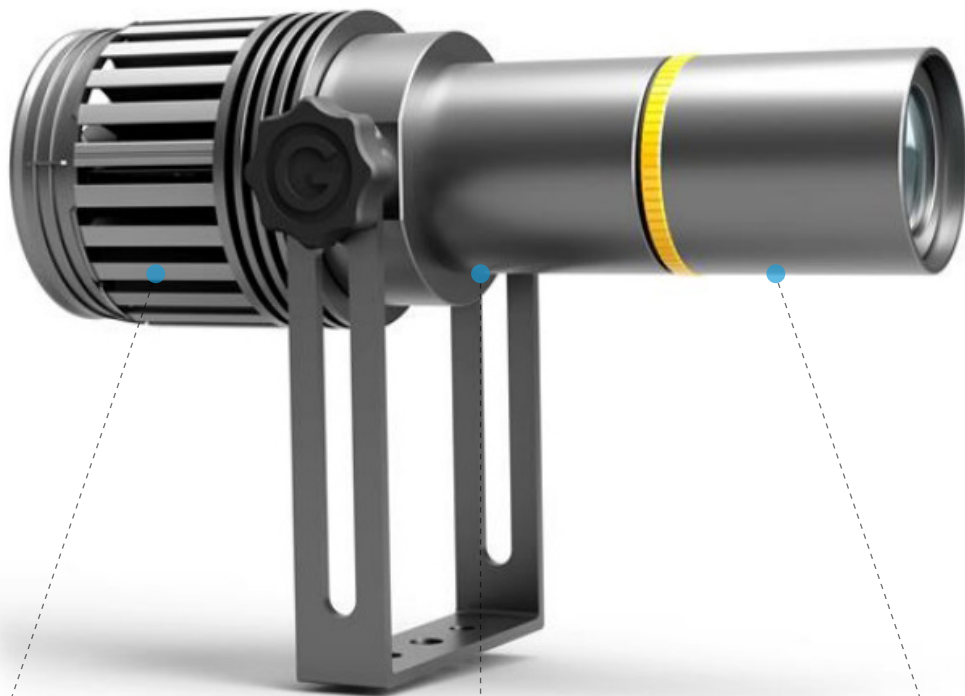

## industrial design suitable to all kinds of operation

- active/passive cooling;
- -30 °C to + 85 °C;
- suitable for humid and dusty environment;



## wide range of different optics

- from 8 ° to 40 ° optics;
- with higher resolution;
- differs according to the environment;



## wide range of ISO safety symbols

- ISO symbols;
- custom symbols;
- large symbols ex. pedestrian crossing;

# ADVANTAGES OF LED FLOOR MARKING

## ELIMINATION OF OPERATIONAL BLINDNESS AND NEAR-MISSES

The safety symbol can either blink, pulse or shine non-stop. Smart activation eliminates operational blindness and reduces work accidents and near misses related to busy traffic.

LED floor marking technology is suitable for marking moving loads especially of the EOT cranes and Green Tire Transport Systems. A projected sign warns of a motion and indicates a position of the hook/load to personnel and other motorized traffic near the crane.

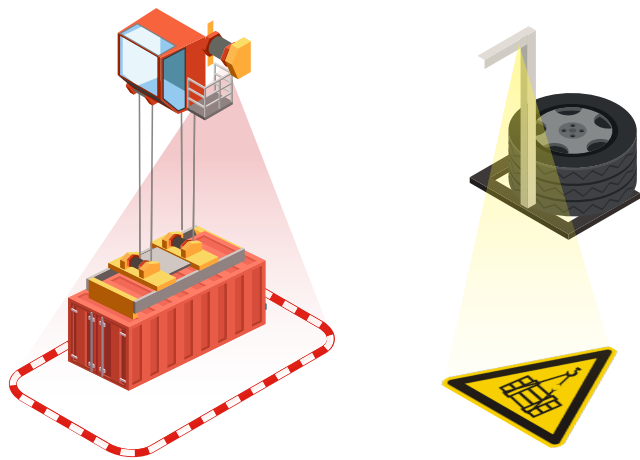

## INTEGRATION TO PARABOLIC MIRROR

The built-in LED projector into the parabolic mirror eliminates the disadvantage of the passive character. The LED projector is triggered by the motion of subjects involved in the intersection.

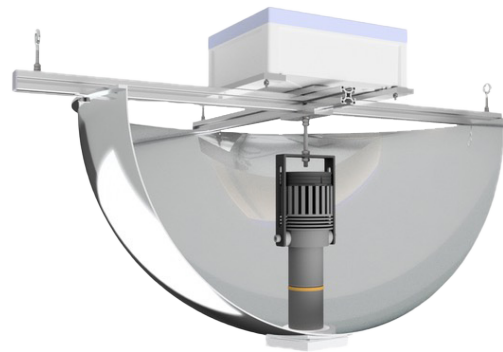

## 1,25 YEAR RETURN ON INVESTMENT

The LED projected sign can not be covered, overlaid, or destroyed by a movement of material handling equipment. **The ROI is in general 1,25 year.**



polyester laminated tape on the highly frequented place

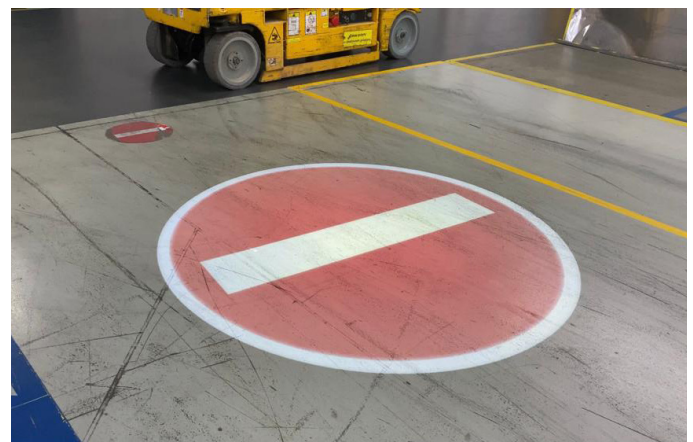

LED projected sign



innovative LED  
floor marking

FLIPPER

CNC

CONDITIONER

OPL

# EXAMPLES OF USAGE

01

## MOVING OBJECTS - INDUSTRIAL MARKING FOR EOT CRANE

Projection of the hazardous zone around the moving suspended load. The size of the final illuminated symbol is set according to the size of the burden. The shape of the safety symbol can either be circular or rectangular - depending on the shape of the load. The projection of hazardous zone around the load can be visible only in case the crane is moving.

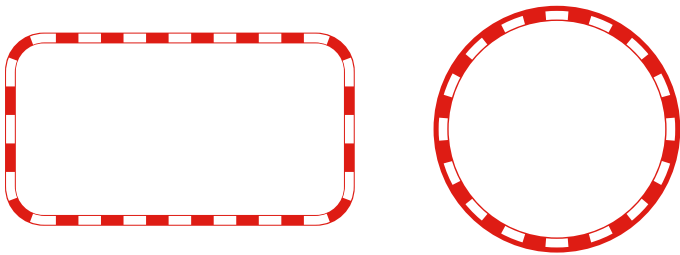

02

## LARGE SYMBOLS - PEDESTRIAN CROSSING

The wide portfolio offers large size symbols like „pedestrian crossing“ or symbols made from more than one sign. The size of the final symbol on the floor depends on the installation height of the projector. For example: 10 m installation height - 600 cm diameter of the symbol for 1 projector.

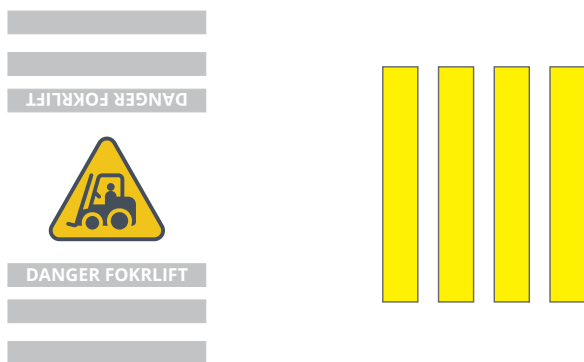

03

## STANDARD ISO SYMBOLS OR CUSTOM DESIGNS

All kinds of ISO standard symbols are available, even own custom design such as the company logo or the combination of standard symbols in one.

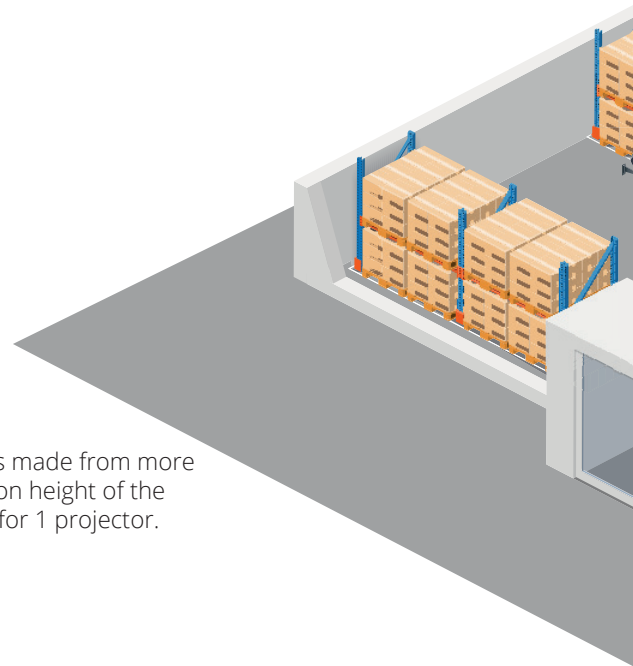



## POSSIBLE FEATURES OF LED FLOOR MARKING



activation by a motion/movement

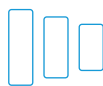

blinking or pulsing



non-stop shining (24/7)

# FIRST CLASS IN SAFETY BE PART OF IT

## SELECTED REFERENCES



ŠKODA

VOLVO



HYUNDAI

SIEMENS

Continental

faurecia



Hydro



Nestlé

Good Food, Good Life

+ 100 ...

ALIS Tech s.r.o.

TUŘANKA 1222/115, SLATINA, 627 00 BRNO CZ

T: +420 739 233 985, E: info@alis-tech.com

www.alis-tech.com

